

NorthStar™ brand Encoder Installation Manual

SERIES HD35R Heavy Duty Encoder

Key Features

- Phased Array Sensor for Reliable Signal Output
- Rugged Design with Wide-Spaced Oversized Bearings
- Unbreakable Code Disc up to 5000PPR
- Improved Seal Design for Increased Moisture Resistance



SPECIFICATIONS

STANDARD OPERATING CHARACTERISTICS

Code: Incremental
Resolution: to 5000 PPR (pulses/revolution) See Ordering Information
Format: Two channel quadrature (AB) with optional Index (Z), and complementary outputs
Phase Sense: A leads B for CW shaft rotation viewing the shaft end of the encoder
Quadrature Phasing: For resolutions to 1200 PPR: $90^\circ \pm 15^\circ$ electrical; For resolutions over 1250 PPR: $90^\circ \pm 30^\circ$ electrical

Symmetry:
 For resolutions to 1024PPR: $180^\circ \pm 18^\circ$ electrical
 For resolutions over 1024PPR: $180^\circ \pm 25^\circ$ electrical
Waveforms: Squarewave with rise and fall times less than 1 microsecond into a load capacitance of 1000 pf

WIRE COLORS

WIRE	PRIMARY FUNCTION	ALTERNATE FUNCTION
Black paired w/ Green	VCC	+UB
Green paired w/ Black	COM	COM
Black paired w/ Blue	A	K1
Blue paired w/ Black	\bar{A}	$\bar{K}1$
Black paired w/ Red	B	K2
Red paired w/ Black	\bar{B}	$\bar{K}2$
Black paired w/ White	Z	K0
White paired w/ Black	\bar{Z}	$\bar{K}0$

ELECTRICAL

Input Power: 5-26VDC, 5-15VDC. 50 mA max., not including output loads.
Frequency Response: 125 kHz (data & index)
Termination: Pluggable screw terminals inside terminal box with M20 cable gland exit

DATA AND INDEX
 Not all complements shown
 \bar{A} shown for reference

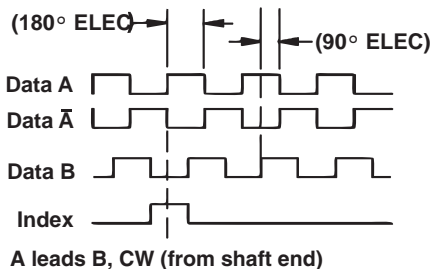

MECHANICAL

Shaft Material: Stainless Steel
Shaft Diameter: 11mm with 4mm key
Shaft Speed: 6000 RPM, Maximum
Starting torque: 12.0 in-oz. maximum (at 25°C)
Running torque: 5.0 in-oz. maximum (at ambient)
Bearings: Deep groove, Dual arrangement
Housing and cover: Hard Anodized Aluminum
Disc material: Mylar (unbreakable)
Weight: 4lb

ENVIRONMENTAL

Standard Operating Temperature: -40 to +85°C.
 At shaft speed above 3000 RPM, derate 10°C per 1000 RPM
Extended Temperature Range: -40 to +100°C
 (See ordering information)
Storage temperature: -40 to +100°C
Shock: 400g, 6mSec
Vibration: 5 to 3000 Hz, 20g
Humidity: 98%, non-condensing
Enclosure Rating: IP67

TERMINAL CONNECTIONS

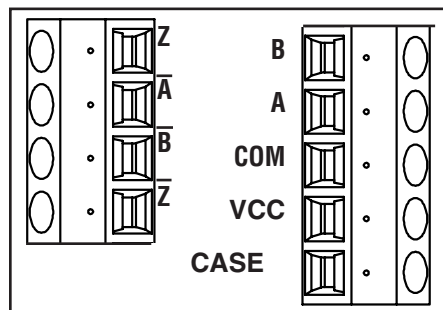

Worldwide Brands: NorthStar™ • Acuro™ • Dynapar™ • Hengstler™ • Harowe™

DYNAPAR™
 INNOVATION - CUSTOMIZATION - DELIVERY
WWW.DYNAPAR.COM

Customer Service:
 Tel.: +1.800.873.8731
 Fax: +1.847.662.4150
custserv@dynapar.com

Technical Support
 Tel.: +1.800.234.8731
 Fax: +1.847.662.4150
northstar.techsupport@dynapar.com

European Sales Representative
 Hengstler GmbH (Germany)
 Uhlandstrasse 49, 78554 Aldingen
www.hengstler.com

Headquarters: 1675 Delany Road • Gurnee, IL 60031-1282 • USA

GENERAL GUIDELINES

Encoders provide quality measurements and long life when common sense, care, and accurate alignments are provided during installation. The following general guide-lines will help to ensure a trouble-free installation.

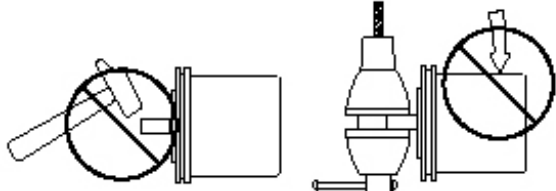

Do not shock the encoder. Do not subject the encoder to axial or radial shaft stresses.

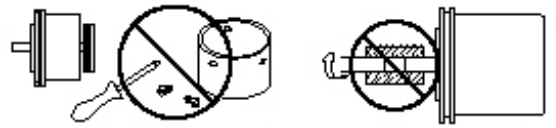

Do not disassemble the encoder. Do not use a rigid coupling.

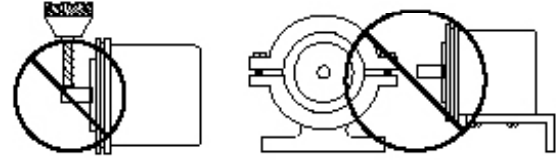

Do not touch the encoder or its shaft. Do not use makeshift techniques to mount the encoder.

Wiring the Encoder

- Never connect or disconnect the encoder connector or wiring while power is ON. Doing so may damage the encoder.
- Power should always be connected to the + side of DC power.
- Common should always be connected to the - side of DC power.
- Never connect A, B, or Z to the + or - side of DC power.

ELECTRICAL CONNECTIONS

Cable - The use of shielded cable is recommended for all encoder installations. When a Dynapar brand encoder is ordered, the type of termination is generally defined (usually the last selectable code in Ordering Information). If a code for a cable was indicated, the encoder was manufactured to include a shielded cable. If any other type of termination was selected or if selection of termination type was not requested, a cable assembly must be ordered. (The cable assembly easily hooks onto the encoder's connector making it ready for wiring).

To determine which cable assembly to order, refer to the Electrical Connections table (in the encoder's manual).

ELECTRICAL CONNECTIONS (cont.)

In some cases, there may be more than one table or the table may be broken into sections due to different output types. If so, refer to the information listed for the output type selected for the encoder (in Ordering Information).

Wiring should be run through dedicated conduits or harnesses (not shared with any other wiring) which are spaced at least 12 inches apart. This protects the cable from physical damage while providing a degree of electrical isolation. Also, do not run cable in close proximity to other conductors which carry current to heavy loads such as motors, motor starters, contactors, or solenoids. Doing so could result in electrical transients in the encoder cable which cause undesired signal pulses.

NOTE: Never connect or disconnect the encoder connector or wiring while power is ON. Doing so may damage the encoder.

Grounding - DO NOT ground the encoder through both the machine and the cable wiring. Connect the shield at the input device only. **NOTE: If the shield is connected at both ends, grounding problems that degrade system performance may result.**

For European-based applications requiring CE compliance, cable length must not exceed 30m. Connect the shield to building ground on either the Encoder or Controls end. CE compliant products are tested to EN61326 EMC.

FEATURES

All encoders have the following electrical features:

- Power (+DC)
- Common
- Output Signal(s)

Power (also referred to as supply, power source, and power +V/VCC) is always +DC for encoders. **Therefore, power should always be connected to the positive (+) side of DC power.** In addition, encoder power should be regulated to within $\pm 5\%$ at the encoder and should be free of induced transients. Common (also referred to as Com, supply common, and ground) is generally a black wire (verify via Electrical Connections table). Common should always be connected to the negative (-) side of DC power.

All encoders have at least one output signal (A); however, it is common for encoders to have three signals A, B, Z (may also be referred to as C, X, or index). The outputs should each be connected to the receiving device at the appropriate terminal. **NOTE: Never connect A, B, or Z to the + or - side of DC power.**

IMPORTANT INSTALLATION INFORMATION

FEATURES (cont.)

When encoders have a differential line driver, there are two signals for each of the outputs. Each signal (A, B and Z) has a compliment or inverse (A, B and Z referred to as A not, B not, and Z not). The signal and its compliment (i.e. A and \bar{A}) are separate outputs. Connect each output to a separate input.

NOTE: Never connect these signals together or to the + or - side of DC power. Never connect differential signals to the same input.

CONNECTIONS

Obviously not all receiving devices are the same. However, connecting your encoder to one, no matter what type or brand it may be, is not difficult. As discussed in the previous section, all encoders have certain electrical features. Each of these features/functions are identified in the encoder's Electrical Connections table along with its corresponding pin and wire color. Each wire specified in the table must be connected to the receiving device.

Determining where to connect each wire is as easy as following the Electrical Connections table and matching each wire to the proper terminal on the receiving device. In general, no matter what type of receiving device you are using, the terminal strip is marked, indicating the proper location for each function/wire. These markings may either be numbers or text labels identifying functions. If they are numbers, the receiving device's manual should define what function corresponds to each number.

Since receiving devices are made by various manufacturers, not all text labels/references are the same. There are various ways to identify each function. Following are a few examples:

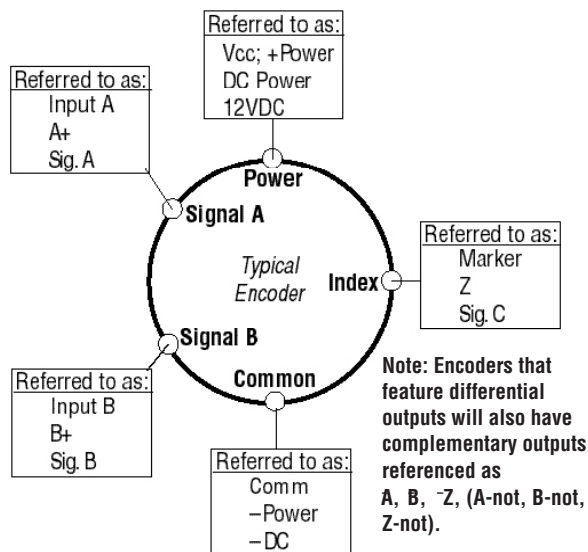

FREQUENTLY ASKED QUESTIONS

There are additional colored wires which are not referred to in the Electrical Specifications table. What do I do with them?

Do not connect them to the receiving device. Any unused encoder signal wires must be individually insulated and tied back. They should NEVER be in contact with common, power sources, or other output signal lines.

The encoder is correctly connected to the receiving device per the Electrical Specifications table and the receiving device's terminal strip label; however, it's counting in the wrong direction. What's wrong?

In order to reverse the counting direction, the output signal connections must be switched. If the encoder has a single ended output, swap A and B. If the encoder has a differential line driver, swap A and \bar{A} .

I've connected the encoder and it doesn't work (No Outputs). What can I do?

Many encoders have internal protection circuits which shut down the encoder to prevent damage if the input power is not correct or the outputs are overloaded. Check the following: Input Voltage (is it too high?); Input Polarity (is it reversed?); and Output Wiring (are they wired properly?).

I've read and followed the technical manual and these guidelines and the encoder still doesn't work properly. Help!?

Calm down - help is at your fingertips! Simply pick up the phone and dial our Applications Engineering Department at 1-800-234-8731 (US & Canada) or 847-662-2666 from 8:00 AM to 4:45 PM (Central time) Monday - Friday. One of our engineers will gladly help you solve the problem.

MECHANICAL INSTALLATION

1. Install Coupling

If you are using Dynapar brand flex couplings, please adhere to the max tightening specification shown.

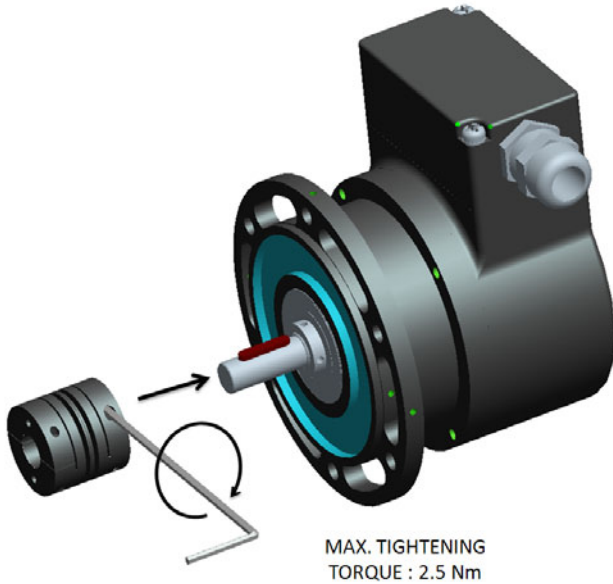

2. Install Flange

Install encoder onto mounting flange or flange adapter using four to six of the screw holes provided on the encoder flange. Through a port in the adapter, tighten the application end of the coupling as shown.

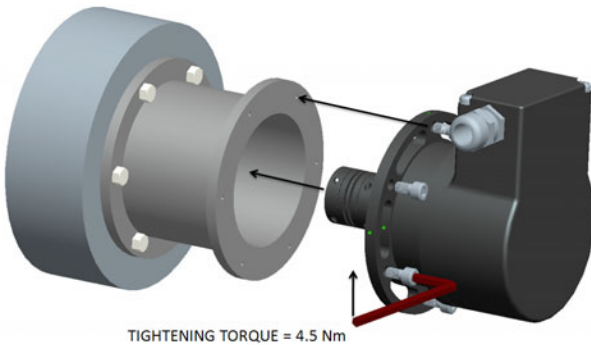

3. Inspect Assembly

Take care that all mounting dimensions and specifications meet the constraints shown below.

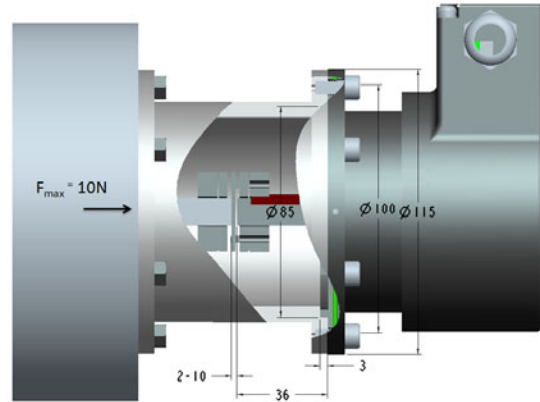

4. Connector cover installation.

- a. Strip main cable jacket 2" from wire end.
- b. Strip each wire used 0.1" from the wire end.
- c. Feed the encoder cable through the strain relief.
- d. Install each wire into the screw terminals of the mating socket matching pin, color, and function, respectfully.
- e. Insert mating socket for the five pin and four pin connectors onto the encoder pins.
- f. Tighten screws on the sides of each connector to secure the mating socket to the encoder pins.
- g. Install main connector cover onto the encoder, and tighten the two screws on opposite corners of the cover.
- h. Tighten the cable strain relief.
- i. Verify that the strain relief is firmly clamped around the complete 360° of the cable outer jacket.

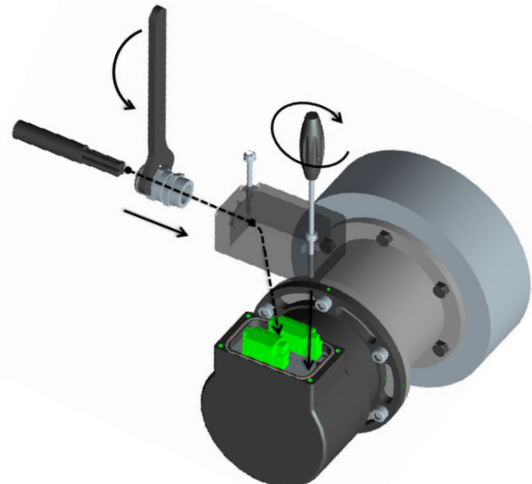

DIMENSIONS inch [mm]

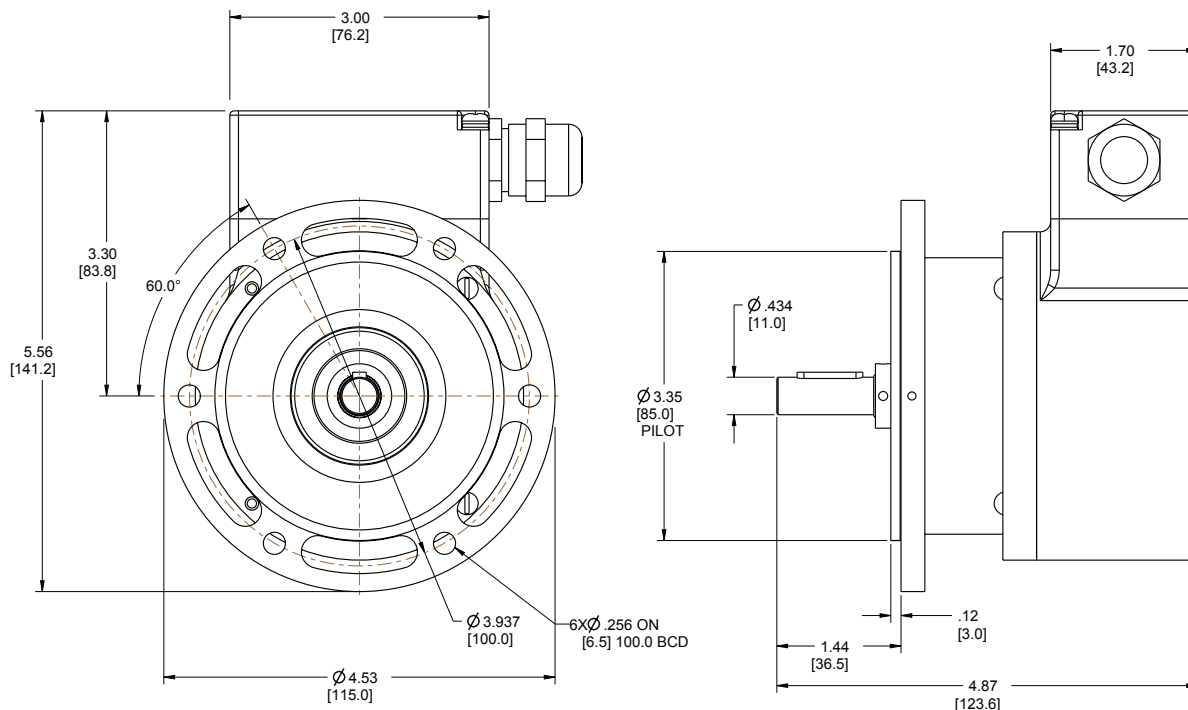

Ordering Information

To order, complete the model number with code numbers from the table below:

Code 1: Model	Code 2: PPR	Code 3: Mounting	Code 4: Output Format	Code 5: Termination	Code 6: Housing	Code 7: Options
HD35R	<input type="checkbox"/>	<input type="checkbox"/>	<input type="checkbox"/>	<input type="checkbox"/>	<input type="checkbox"/>	<input type="checkbox"/>

Ordering Information						
HD35R Heavy Duty IEC Flange Encoder	0001 0003 0010 0012 0015 0032 0050 0060 0100 0120 0200 0240 0240 0250 0300 0360 5000	0500 0512 0600 0900 1000 1024 1200 1500 2000 2048 2400 2500 3072 4000 4096 5000	0 100mm IEC "Euro" flange, 11mm shaft w/ 4mm key	0 Single Ended ABZ, 5-26VDC push-pull 1 Single Ended ABZ, 5-26VDC O/C 2 Single Ended ABZ, 5-26VDC O/C w/2.2kOhm H Same as "0" with Extended temp range J Same as "1" with Extended temp range K Same as "2" with Extended temp range 4 Differential AB only, 5-26VDC, 5-26VDC out *(7272) 5 Differential AB only, 5-26VDC in, 5VDC out *(7272) A Differential AB only, 5-15VDC in, 5VDC out *(4469) C Differential AB only, 5-15VDC in, 5-15VDC out *(4469) L Same as "4" with Extended temp range M Same as "5" with Extended temp range 6 Differential ABZ, 5-26VDC in, 5VDC out *(7272) 7 Differential ABZ, 5-26VDC in, 5-26VDC out *(7272) 8 Differential ABZ, 5-15VDC in, 5VDC out *(4469) 9 Differential ABZ, 5-15VDC in, 5-15VDC out *(4469) N Same as "6" with Extended temp range P Same as "7" with Extended temp range W ABZ, 10-24VDC Line Driver for over 80 meter cable runs * Line Driver Type	0 Terminal Box, M20 gland	0 Anodized Aluminum 01 Wind Label

Accessories: 114917-001, Isolated coupling, 11mm



Worldwide Brands: NorthStar™ • Acuro™ • Dynapar™ • Hengstler™ • Harowe™

DYNAPAR™
INNOVATION - CUSTOMIZATION - DELIVERY
WWW.DYNAPAR.COM

Headquarters: 1675 Delany Road • Gurnee, IL 60031-1282 • USA

Customer Service:

Tel.: +1.800.873.8731
Fax: +1.847.662.4150
custserv@dynapar.com

Technical Support

Tel.: +1.800.234.8731
Fax: +1.847.662.4150
northstar.techsupport@dynapar.com

European Sales Representative

Hengstler GmbH (Germany)
Uhlandstrasse 49, 78554 Aldingen
www.hengstler.com