

NorthStar[™] brand

Instruction Manual

RIM Tach[®] HS85 Hollow Shaft Digital Tachometer

Designed for use in
motor shaft sizes 1.000”(25.4mm) to 4.500”(115mm) diameter

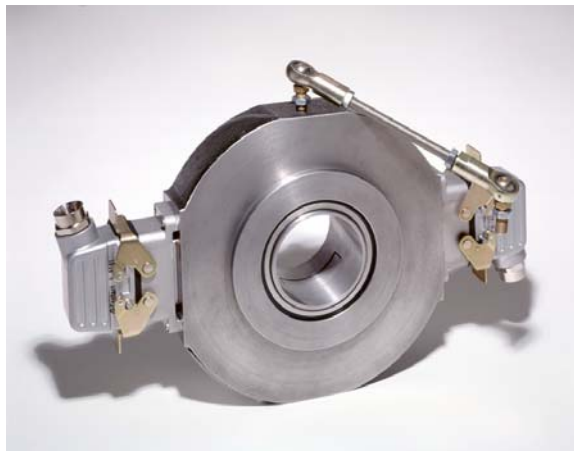

Customer Service:
Tel.: +1.800.873.8731
Fax: +1.847.662.4150
custserv@dynapar.com

Technical Support
Tel.: +1.800.234.8731
Fax: +1.847.782.5277
northstar.techsupport@dynapar.com

Website: www.dynapar.com

*** 791-1006-00 ***

Table of Contents

Chapter/Paragraph/Illustration	Page
1 Introduction.....	3
1.0 Safety Summary.....	3
1.1 General.....	4
1.2 Description.....	4
<i>Figure 1: RIM Tach® HS85 Front/Side View.....</i>	<i>4</i>
1.3 Specifications.....	5
1 Installation.....	6
2.0 Inspection and Unpacking.....	6
2.1 Painting Considerations.....	6
2.2 Mechanical Installation.....	6
<i>Figure 2: Encoder Housing Orientation.....</i>	<i>7</i>
<i>Figure 3: Clamping Ring Segment.....</i>	<i>7</i>
<i>Figure 4: Anti-Rotation Arm Orientation.....</i>	<i>8</i>
2.2.1 Sensor Module Installation.....	8
<i>Figure 5: Sensor Module Installation.....</i>	<i>9</i>
2.3 Electrical Installation.....	9
2.3.1 Quick Release Connector Hood Wiring.....	10

Methods and apparatus disclosed and described herein have been developed solely on company funds of Dynapar. No government or other contractual support or relationship whatsoever has existed which in any way affects or mitigates proprietary rights of Dynapar. in these developments. Methods and apparatus disclosed herein may be subject to U.S. Patents existing or applied for. Dynapar. reserves the right to add, improve, modify, or withdraw functions, design modifications, or products at any time without notice. Dynapar shall not be liable for errors contained herein or for incidental or consequential damages in connection with furnishing, performance, or use of this material.

CHAPTER 1

INTRODUCTION

1.3 Safety Summary

High current, voltage, and rotating parts can cause serious or fatal injury. The use of electric machinery, like all other uses of concentrated power and rotating equipment, may be hazardous. Installing, operating, and maintaining electric machinery should be performed by qualified personnel, in accordance with applicable provisions of the National Electrical Code and sound local practices. Failure to comply with these precautions or with specific warnings elsewhere in this manual violates safety standards of design, manufacture, and intended use of the instrument. Dynapar assumes no liability for the customer's failure to comply with these requirements.

Rotating Machinery

Avoid contact with rotating parts. Avoid by-passing or rendering inoperative any safety guards or protection devices. Avoid extended exposure in close proximity to machinery with high noise levels. Use proper care and procedures in handling, lifting, installing, operating and maintaining the equipment.

Before Installation

Safe maintenance practices with qualified personnel is imperative. Before starting maintenance procedures, be positive that, (1) equipment connected to the shaft will not cause mechanical rotation, (2) main machine windings have been disconnected and secured from all electrical power sources, and (3) all accessory devices associates with the work area have been de-energized. If high potential insulation test is required, follow procedures and precautions outlined in NEMA standards MG-1.

Grounding

Improperly grounding the frame of the machine can cause serious or fatal injury to personnel. Grounding of the machine frame and structure should comply with the National Electrical Code and with sound local practices. Check wiring diagram before connecting power.

Do Not Operate In An Explosive Atmosphere

Do not operate the instrument in the presence of flammable gases or fumes. Operating any electrical instrument in such an environment constitutes a definite safety hazard.

Keep Away From Live Circuits

Operating personnel must not remove instrument covers. Component replacement and internal adjustments must be made by qualified maintenance personnel. Do not replace components with power cable connected. To avoid injuries, always disconnect power and discharge circuits before touching them.

Do Not Substitute Parts Or Modify Instrument

Do not install substitute parts or perform any unauthorized modification to the instrument. Introducing additional hazards is dangerous. Return the instrument to an authorized Dynapar representative for service and repair to ensure that safety features are maintained.

Dangerous Procedure Cautions

A CAUTION heading precedes potentially dangerous procedures throughout this manual. Instructions in the warnings *must* be followed.

1.1 General

These instructions do not claim to cover all details of variation in equipment or to provide for every possible contingency or hazard to be met in connection with installation, operation, and service. Should further information be desired or should particular problems arise which are not covered sufficiently for the purchaser's purposes, please contact Dynapar, or one of its designated representatives.

1.2 Description

The RIM Tach[®] HS85 is a mill duty digital tachometer accommodating large thru-shaft sizes up to 4.500" or 115mm tapered or straight shafts, and can easily mount to most AC or DC fan cooled motors. This digital tachometer offers the same reliability, resolution, and flexibility you have come to know with NorthStar. The RIM Tach HS85 provides for reduced down time, easy maintenance and fast installation.

The RIM Tach[®] HS85 was designed as a solution to roller or sleeve bearing motors with excessive axial and radial play. This digital tachometer is ruggedly designed with steel flanges, heavy duty motor style bearings, and uses a cast iron housing. The mill duty construction is ideal for motor and non-motor applications where the motor C-Face is otherwise unavailable or the shaft exhibits large axial or radial runouts. For example, the Model HS85 is perfect for mounting as a Line Shaft Reference Encoder. By virtue of design, The RIM Tach HS85 is more forgiving of motors which are unable to hold precise tolerances.

The RIM Tach[®] HS85 incorporates state-of-the-art magnetoresistive sensing technology. The magnetically encoded signals provide pulse codes of A, B, and an optional index pulse with complements. These signals are solid for the life of the encoder. They do not exhibit the unreliable signal, which then drift requires a fault check on other digital tachometers. In addition, this technology is virtually immune to common mill environments such as water, oil, grease, dirt, vibration, and overall harsh conditions of operation.

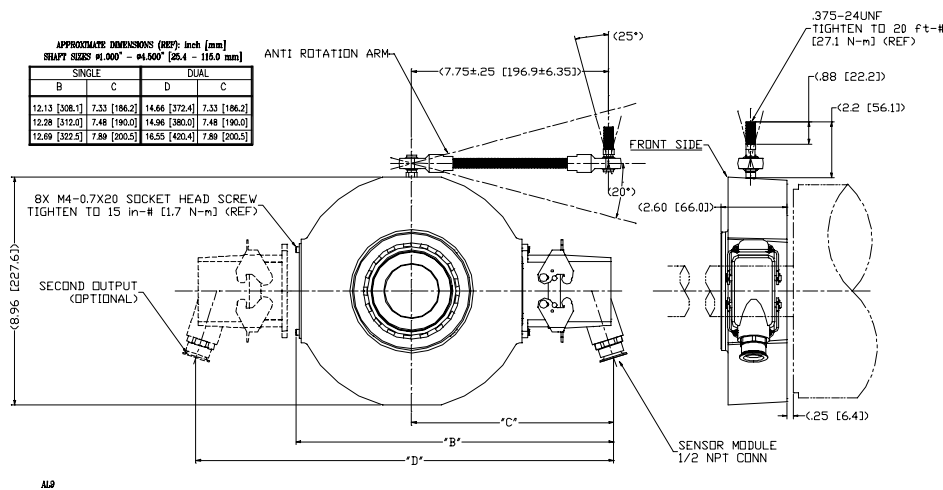

Figure 1: RIM Tach[®] HS85 Front/Side View

1.3 Specifications

Electrical Specifications	
Resolution	60, 64, 75, 120, 128, 150, 240, 256, 300, 480, 480Z, 512, 512Z, 600, 600Z, 960, 960Z, 1024, 1024Z, 1200, 1200Z, 2048, 2048Z
Frequency Response	0 - 120 kHz
Pulse Code	A, B, Z (Index), and complements (A, B, Z)
Output Phases	A phase, B phase @ quadrature 90°; Z phase: One per rev. (gated)
Pulse Duty Cycle	50 ± 15% (within defined mechanical specifications)
Quadrature Accuracy	90 ± 22° (within defined mechanical specifications)
Output Type	High speed, differential line driver,
Rise and Fall Time	Less than 1µs @ 10,000 pf typical load
Current Consumption	45mA typical plus line driver load
Output Current	150mA maximum continuous
ESD Protection	2kV
Mechanical Specifications:	
Maximum Operational Speed	3,600 RPM
Enclosure Material	Ductile iron casting, steel flanges
Radial Runout	.010" Total Indicated Runout
Allowable Axial Movement	0.25" max.
Weight	25lbs. Typical
Environmental Specifications	
Operational Temperature	-40° to +70° C
Operational Humidity Range	Maximum of 90%
Chemical Resistance	Salt spray, most solvents, mild acids and bases
Vibration	Minimum 18 g's RMS, 5 - 2000 Hz shock spectrum
Shock (Sensor Module)	1 meter drop tested, min. 30g's
Interface Specifications	
Power	+5.0 to +15.0 VDC
Output	Differential output swinging between Vcc - 0.6V and ground
Connector	10 pin industrial latching connector with ½ inch NPT fitting, IP-65 NEMA 4, 12 rated
Suggested Cable	22 - 14 AWG, 6 conductor, shielded, twisted pair

Specifications subject to change without notice.

CHAPTER 2

INSTALLATION

2.0 Inspection and Unpacking

Inspect shipping container for external damage. All claims for damage (apparent or concealed) or partial loss of shipment must be made in writing to Dynapar within (5) days from receipt of goods. If damage or loss is apparent, please notify the shipping agent immediately.

Open shipping container and locate the packing list. The packing list is included to verify that all components, accessories, and a manual were received. Please use the packing list to check off each item as the unit is unpacked. Inspect for damage. Dynapar recommends that the shipping container be retained for future shipping, storage, or return to factory purposes.

If any equipment was damaged in transit, be sure to file proper claims promptly with the carrier and insurance company. Please advise Dynapar of such filing. In case of parts shortages, advise Lake Shore immediately. Dynapar cannot be responsible for any missing parts unless notified within 60 days of shipment.

2.1 Painting Considerations

The RIM TACH enclosure may be painted. Please pay attention to the following considerations.



Corrosion preventative grease may have been applied to the enclosure. Standard degreasing practices must be followed before applying paint.

- Do not hinder the latches on the connector if the connector is painted.
- If the enclosure is painted before the sensor module(s) is added, be sure to mask off the area where the sensor module(s) will be placed. The module must mate directly to the enclosure with nothing between. Failure to do this will degrade the alignment of the system and may cause it to fail.
- Enclosure drain holes must be covered for painting.

2.2 Mechanical Installation

The RIM Tach[®] HS85 is shipped partially assembled. There are no field gap checks, axial alignment, or run out checks required. Sensor Module shimming may be required. The interchangeable stainless steel sensor modules are available in a wide variety of pulse counts. After unpacking the unit and verifying receipt of the items listed on the packing list, proceed with mechanical installation.

1. Place an anti-seizing agent such as a light moly-grease or other high temperature, stable corrosion inhibitor on motor shaft. This will aid not only installation but future removal of the encoder for maintenance, repairs, etc., and lessens chances for corrosion.
2. Slide encoder housing onto motor shaft with flange surface (back side-see Figure 2) facing the motor, and tilted so the sensor head is facing downward. In this orientation, the B channel will lead the A channel when shaft rotation is CCW.

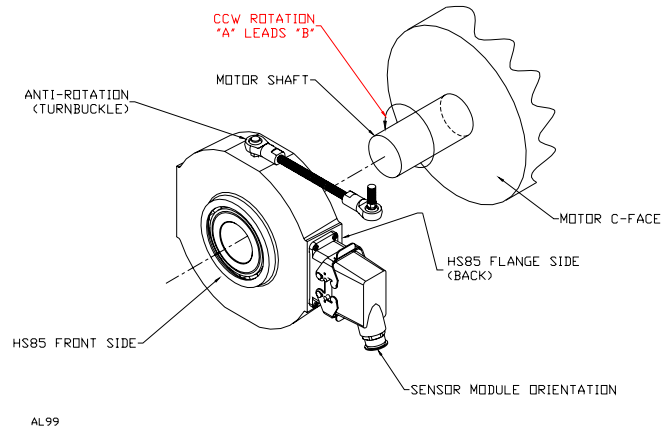

Figure 2: Encoder Housing Orientation

3. Remove black, trapezoidal access plate from the encoder housing using an M4 (DIN 912) metric hex wrench (not included). Once removed, the clamping ring segment is now available for tightening.



Dual units require a hex wrench to remove a module.

4. Tighten the clamping ring segment as follows (see Figure 3):
 - 1) Look inside the access plate hole and rotate the hollow shaft until the two M5-0.8x12 mounting screw heads on clamping ring are visible.
 - 2) Being very careful not to damage the magnetic pulse wheel (black disk, see Figure 3 below), tighten down both mounting screws using the M4 T-Handle hex wrench (included). Torque each mounting screw to 55 in-lbs (6.3 N-M regular) nominal, while ensuring gaps on both radial ends of clamping ring segment are approximately equal.



Be very careful not to touch the pulse ring when tightening the cap screws. The pulse ring is near the screws and can be damaged easily. The surface of the pulse wheel outer rim is sensitive to scratches and impacts. The magnetic properties of the pulse wheel material can also be distorted or erased by exposure to strong magnetic fields.



Do not unscrew the (2) cap screws on the clamp ring completely, either when un-installing or servicing the encoder. The screws may fall inside the unit and would be difficult to retrieve.

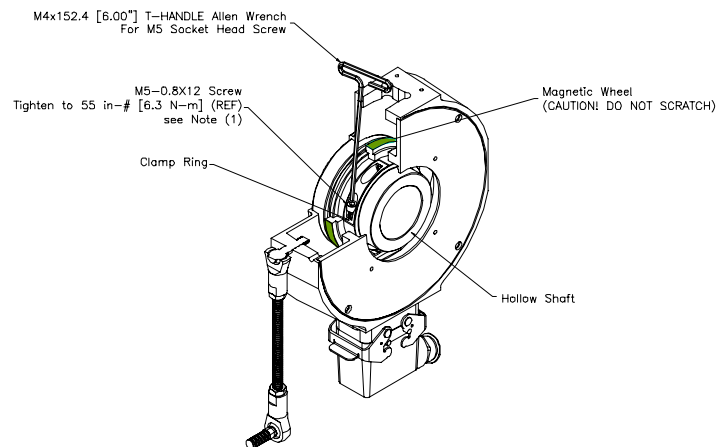

Figure 3: Clamping Ring Segment

5. Reinstall the access plate back onto encoder housing, or place second sensor module assembly.
6. Attach/insert anti-rotation arm into the threaded hole (3/8"-24 UNF) in the encoder housing (see Figure 4). Complete approximately 10 turns of the anti-rotation arm into stud. Tighten locking nut (using a 9/16" open wrench) against the encoder housing.

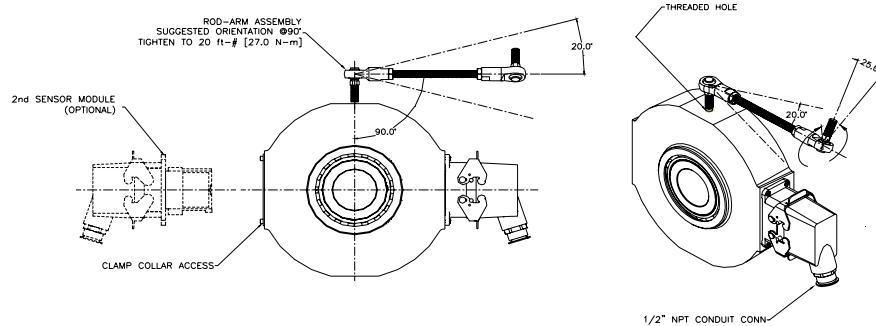

Figure 4: Anti-Rotation Arm Orientation

7. Position anti-rotation arm at a 90° angle to the motor shaft (perpendicular to motor axis and motor C-face is recommended). This orientation ensures three things:
 - It provides enough clearance between the HS85 encoder and point of attachment (weldment angle or channel bracket, motor face or foot, or other stable mounting)
 - It gives long moment arm from encoder centerline, thus minimizing housing rotation and encoder error caused by relative rotation
 - It reduces misalignment of bearing rod ends which prevents binding and premature wear due to high degrees of angular misalignment
8. Loosely adjust anti-rotation arm to desired length. Apply removable thread locker (example: Loctite 942) on threaded rod where bearing rods will rest (sample tube in hardware kit). The free end of the anti-rotation arm should then be mounted to a stationary surface such as a welded channel, angle, motor flange, or foot. Tighten locking nuts (using a 9/16" open wrench) against bearing rod ends and mounting stud.



Do not disrupt the anti-rotation arm's 90° alignment with the motor shaft during mounting. A parallel orientation between the anti-rotation arm and motor shaft is not recommended because it will significantly reduce the anti-rotation arm's performance and operational lifetime. Each rod end can withstand only 50° of deviation. Ideally, the anti-rotation arm should be mounted with rod-end ball centered in its socket. Recommended torque: 20 ft-lbs. [27 N-m].

2.2.1 Sensor Module Installation

To install the Sensor Module, perform the following steps. See Figure 5.

1. Remove sensor module and mating connector from packaging.



Although the device is protected from Electrostatic Discharges up to 2000 Volts, standard ESD precautions should be followed.

2. Separate mating connector from sensor module by releasing the two latches.



Use caution when handling the sensor module. The sensor at the end of the module can be easily damaged by sharp objects. The sensor module can be damaged by sudden shocks (dropping, hammer blows, etc.).

3. Insert sensor module into opening in enclosure. The sensor assembly is keyed to ensure proper orientation.
4. Locate four M4-0.7 socket head screws. Insert the screws through clearance holes in sensor module and into tapped holes in enclosure. Tighten to a nominal 15 in-lbs [1.7 N-m regular].



There should not be a gap between the lip on the housing and the enclosure. The stainless steel sensor module is designed to seat in metal to metal contact with the enclosure. Ensure that no gaskets, paint, dirt, etc., interferes with the complete seating of the module in the enclosure.

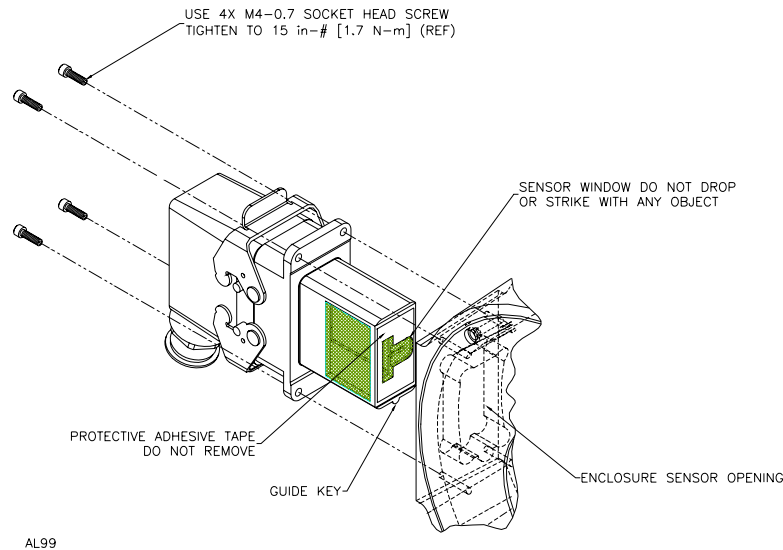

Figure 5: Sensor Module Installation

2.3 Electrical Installation

IT IS VERY IMPORTANT that the mating connector and the encoder body be isolated from electrical ground in the wiring and conduit to prevent motor or machine shaft eddy currents from going to ground through the encoder bearings, as this will damage the bearings over time. To insure that this is being done, it is suggested that a plastic wiring/conduit adaptor or non-conductive conduit is used to isolate the connector from any metallic surface or conductive conduit. Please see special note under table 1, for proper encoder connector shielding. Also, to allow for proper encoder grounding, the motor must be wired and grounded per your local NEC Requirements.

Electrical connections are made to the sensor module through a standard 1/2 inch NPT liquid tight flexible conduit. The nipple length may be changed to extend the outlet box if desired. Interconnection cable recommendations are as follows: stranded copper, 22 through 16 gage, braided or foil with drain wire shielding 0.05 μ F maximum total mutual or direct capacitance, outer sheath insulated. Shrink tubing may be placed over any wires without insulation. For lengths over 100 feet, use 18 gage or larger, to a maximum of 1000 feet. If shielded twisted pair wire is used, do not cross channels. Keep each pair of complementary channel outputs together in a single twisted pair (e.g., A and A).



Reversing power and common will not damage the unit. However, applying power to any of the sensor outputs may cause damage.

Table 1. Signal Coding Table

Signal	Connector Pin	Pigtail Cable	MS 3102E18-IT#
Common	1	Black	A
B	2	Green	E
A	3	Blue	D
Z *	4	Violet	C
No Connection	5	-----	-----
Vcc (5-15 VDC)	6	Red	B
/B	7	Yellow	H
/A	8	Gray	G
/Z *	9	Orange	I
Shield	10	Braid	J

* Applies only to units with index pulse capability.
 # Pinouts are for the sensors with the MS 3102E18IT connector



The shield in the sensor module is isolated from the frame of the encoder for maximum noise immunity. The shield wire or pin should be connected to the shield of the cable and that of the drive or other receiving device.

2.3.1 Quick Release Connector Hood Wiring

To install the Quick Release Connector, perform the following steps.

1. Remove the four screws from the mating connector housing that hold the terminal block in place. Remove terminal block from housing.
2. Insert wiring through liquid tight flexible seal and mating connector housing. Leave enough wire exposed to comfortably reach the terminal block. Wire to terminal block according to wire code in Table 1. A similar wiring list is attached to enclosure.



There are two orientations of the connector hood. The terminal block can be inserted either way so the connector hood points up or down. Choose the direction best for your application.

4. Tighten Liquid Tight fitting on housing. **OPTIONAL:** In some hostile environments, seal between connector body and Sensor Module can be improved by smearing a sealant (silicone grease, etc.) on the neoprene seal of the connector.
5. Mate connector into place on sensor mount and snap the two latches into place. If only one sensor is being installed, ensure cover plate is installed over other sensor hole.