

HENGSTLER



热线电话/Hotline

+400 666 1802

福迪威西特传感工业控制（天津）有限公司

天津市西青区泰达微电子微五路28号, 300385

<http://www.hengstler.com.cn>

E-mail:info@hengstler.com.cn

Fortive Setra-ICG Tianjin Co. Ltd.

Weiwu Road 28, TEDA Micro-Electronics Industrial Park

300385 Tianjin/ China

<http://www.hengstler.com.cn>

HENGSTLER

CN

多圈绝对值编码器

AD38

安装手册

GB

MT Absolute Encoders

AD38

Installation instructions

物料号/Art No.: 703347-0001

版本Ver. B

European Sales Representative

Hengstler GmbH

Uhlandstr. 49 D-78554 Aldingen/ Germany

CN

1. 前言

这个安装手册提供连接和开始使用这个编码器的流程。

你可以从AD38的数据手册获得更多信息，可以联系我们或者从网站下载。

www.hengstler.com.cn

GB

1. Preface

These installation instruction are provided for the connection and starting procedure of your hollow shaft encoder.

You will get further information from the AD38 datasheet, on request or on download from our Internet site.

www.hengstler.com.cn

CN

2. 安全



有资质的操作人员

因为编码器包含敏感的电子电路，所以编码器必须由合格的电工进行安装和拆卸。

旋转的轴造成伤害的风险

头发或者衣服上的东西可能被旋转的轴卷进去。

->开始所有工作前，先切断所有电源并且确保工作环境的安全！

静电(ESD)造成损坏的风险

注意防静电操作注意事项。编码器，包括外壳是一个静电放电灵敏装置。

->不要接触插头的触点或者电子器件！

机械过载造成的损坏风险

刚性安装将使约束力增加，并且将造成轴承的永久过载。

-> 不要限制编码器的移动！只使用附带的钢弹簧片或者合适的联轴器确保编码器安全！

机械冲击造成损坏的风险

猛烈的冲击，例如锤子的敲击，可以导致光电传感系统和滚珠轴承的损坏。

-> 不要用力过猛！正确安装过程中的力量是允许的。

超限使用造成的损坏风险

-> 装置只能在技术指标的极限范围内工作。

应用场合：工业过程和控制

连接端子的过电压必须被限定在过电压等级II值以内 (SELV).



GB

2. Safety



Authorized persons

The encoder should only be assembled and dismantled by a qualified electrician, as the unit contains sensitive electronic circuits.

Risk of injury due to rotating shafts

Hair and items of clothing may become caught up in rotating shafts.

->Prior to commencing all works, disconnect all power suppliers and ensure that the working environment is Safe!

Risk of destruction due to ESD

Observe Precautions for ESD Handling. The Encoder, including housing is an electrostatic discharge sensitive device.

->Do not touch plug contacts or electronic components!

Risk of destruction due to mechanical overload

Rigid mounting will give rise to constraining forces which will permanently overloaded the bearings.

-> Never restrict the freedom of movement of encoder! Use only the enclosed sheet steel springs or a suitable coupling to secure the unit!

Risk of destruction due to mechanical shock

Violent shocks, e.g. due to hammer blows, can lead to the destruction of the optical sensing system and the ball bearings.

-> Never use force! Assembly is simple provided that correct procedure is followed.

Risk of destruction due to overloading

-> The unit may only be operated within the limits specified in the technical data.

Fields of application: industrial processes and controls.

Over voltage at the connecting terminals must be limited to over voltage-class-II values (SELV).

The connecting cable is not for dragline mounting, only for fix mounting.

This encoder is a supply part destined for mounting to an appliance (motor, machine). It is not provided for customer sale.

Manufacturers integrating this encoder to their facilities are responsible as well for compliance with CE guidelines as for the CE mark.



3. 安装 / Assembly

1

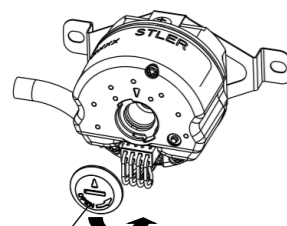

逆时针旋转卸下塞子
CCW rotate the lip and remove it

2

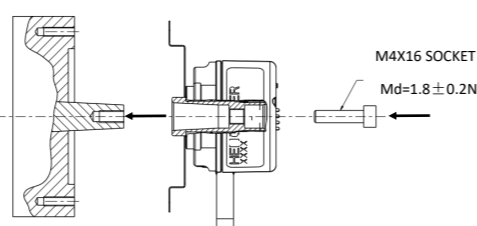

M4X16 SOCKET HEAD
Md=1.8±0.2Nm

3

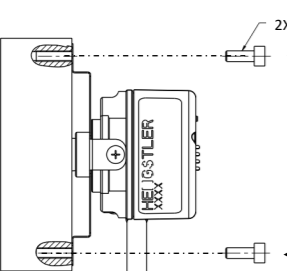

2XM3x10 Md=0.8±0.1Nm

4

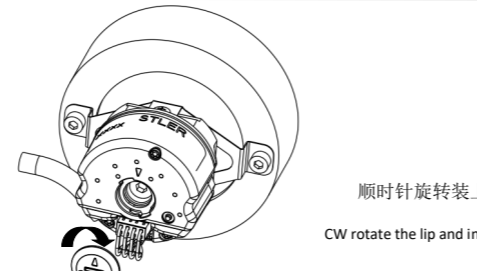

顺时针旋转装上塞子
CW rotate the lip and install it

3.1 要求的匹配尺寸 / Required mating dimensions

I.OJ 40mm Tether

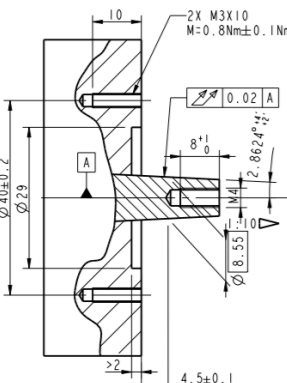

L.OJ 55mm Tether

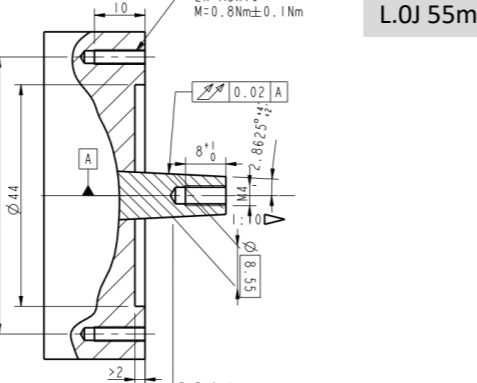

4. 拆卸 / Dismounting

1

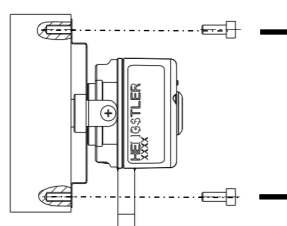

逆时针旋转卸下塞子
CCW rotate the lip and remove it

2

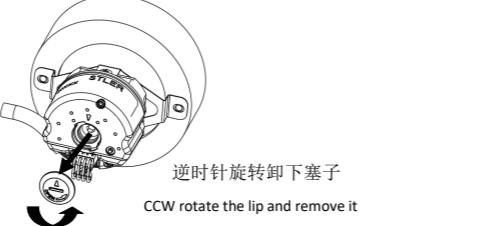

M4x10 SET SCREW

3

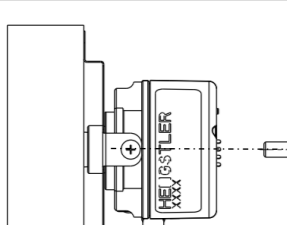

M5x20 SOCKET HEAD SCREW

6

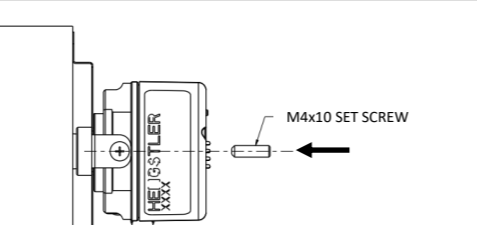

使用M5螺钉将编码器从电机锥轴上顶下来
USE M5 SCREW REMOVE ENCODER FROM THE HOLLOW TAPER SHAFT

4. 拆卸 (续) / Dismounting continue

7

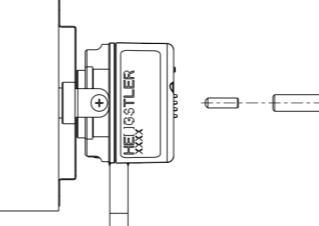

M5x20 SOCKET HEAD SCREW

8

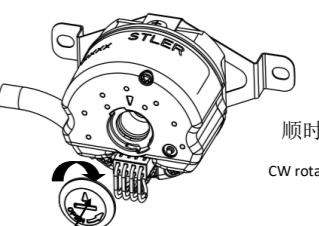

顺时针旋转装上塞子
CW rotate the lip and install it

5. 技术数据 / Technical data

供电电压 Operating Voltage	5V±5% (SELV)	存储温度 Storage Temperature	-30°C~+80°C	工作温度 (M1) Operating Temperature (M1)	-40°C~+115°C
电源消耗 Power consumption	<1W	最大相对湿度 Max. relative humidity	85%	环境温度 (M2) Ambient Temperature (M2)	-40~+105°C @ 6,000rpm -40~+100°C @ 8,000rpm -40~+95°C @ 10,000rpm
最高转速 Max Speed	10,000 PRM	最大运行海拔高度 Max. Altitude for operation	2,000 m		
允许轴最大轴向跳动 Mating shaft axial move-	±0.5 mm	污染等级 Degree of pollution	2		
允许轴最大径向跳动 Mating shaft runout	TIR 0.05 mm	重量 Weight	70 g		
外壳防护等级 Enclosure rating	IP40				

6. 电气连接 / Connection diagram

PIN	颜色 Color	定义 Assigment	PIN	颜色 Color	定义 Assigment
1A	紫 Violet	Temp+	1B	紫/黑 Violet/Black	Temp-
2A	绿/黑 Green/Black	DATA-	2B	绿 Green	DATA+
3A	蓝/黑 Blue/Black	CLOCK-	3B	蓝 Blue	CLOCK+
4A	红 Red	UB+	4B	黑 Black	GND

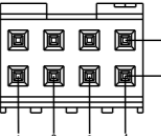

7. 订货代码 / Ordering information

7.1 中文

型号	分辨率	供电电压	法兰, 防护等级, 轴	通信界面	连接
AD38	0024 24 位单圈 1224 24 位单圈+12 位多圈	A 5 VDC	I.OJ 40mm弹簧片, IP40 9 mm 1:10锥孔 L.OJ 55mm弹簧片, IP40 9 mm 1:10锥孔	BE BiSS-C BT BiSS-C + 电机绕组 温度 *BT型需驱动协议匹配	B 数据和电源8针轴向 PCB插座,0.5米电缆

7.2 English

Type	Resolution	Supply Voltage	Flange, IP, Shaft	Output	Connection
AD38	0024 24 Bit ST 1224 24 Bit ST +12 Bit MT	A 5 VDC	I.OJ 40mm Tether, IP40 9 mm 1:10 hollow shaft L.OJ 55mm Tether, IP40 9 mm 1:10 hollow shaft	BE BiSS-C BT BiSS-C + Temper- ature sensor *BT need driver function support	B 8 pole PCB con- nector + 0.5m cable