

Introduction

This installation manual is provided for the connection and starting procedure of your cutter.

Further informations like e.g. dimensioned drawings are available in our Printers and Cutters Catalogue or on request. The devices of the type H (0685.2 ...) model series are electric motor driven paper cutters. The paper is cut by a double-edged rotary knife. Thus two cuts can be made per one single turn of the knife. These models allow the following triggering of the drive motors:

K = Cutting is triggered by applying nominal voltage via mechanical SPDT contacts

The cutters of these model series are available in various versions, depending on the paper width and the operating voltage.

Safety Instructions

This cutter is a quality product manufactured in accordance with established electrical engineering standards. The unit has been delivered from the factory in perfect conformance to safety regulations. To maintain this condition, please observe all notes and warnings in this document!

- Installation and mounting of electrical devices may only be performed by an electrotechnical expert!
- When installing and mounting the cutter, please observe the demands made on the whole facility by the respective device safety regulation.
- The cutter may only be used for the purpose it was designed for – i.e. for cutting paper strips.
- The cutter is designed complying with EN 60950, protection class III. To prevent dangerous structure-borne currents, the equipment has to be run on safety extra-low voltage (SELV) and must be in an area of equipotential bonding.
- The cutter may only be operated within the limits specified by the technical data. Maximum operating voltages must not be exceeded!
- Hengstler Cutters are designed for industrial use.
- Installation environment and cabling have a very significant influence on Electromagnetic Compatibility (EMC). When installing the cutter sub-assembly in a complete unit, you should seek guarantees from the manufacturer of the complete unit regarding EMC.



Caution: Danger!

- The rotary knife has two sharp cutting edges! Therefore never reach into the cutting area, e.g. for removing jammed material! Only use tweezers, tongs or the like for this purpose (do not damage the knife)!
- It is expressly emphasized that the cutter is to be started only when completely installed, i.e. the knife is covered on all sides and the material feed and delivery slot are dimensioned such that, e.g., small children cannot reach into the cutting area.
- Installation or servicing works are to be carried out only when the power supply lines are disconnected from the cutter!
- If safe operation is not possible any more, the cutter has to be set out of order and to be protected against unintended starting.

Operating Instructions

- Do not cut self-adhesive labels! The traces of adhesive will pollute the rotary knife and impair safe operation!
- During the cutting process, there must be no paper feed.
- Please make sure that the cutter remains free from shreds of paper.
- Having applied voltage, please ensure that the rotary knife is in home position before paper is fed.
- If the cutter doesn't have internal switching (page 3 of 4), the user must install a suitable safety switch to ensure that power is removed from the cutter within a max. of 10 seconds in the event of a breakdown, such as a jammed cutter. If this is not done, the motor may be damaged through overheating.
- Do not use cleansing agents containing solvents.

Installation Instructions

- The cutter must be installed in the intended unit before connecting the power lines!
- The cutter can be installed in any position. The strips cut off, however, must not collect in the cutting area, thus blocking the rotary knife!
- The cutter is attached by means of two M3 screws.
- Install the cutter in the unit/housing such that paper transport is smooth. Electrically connect the cutter to the control system and power supply when these are switched off. You will find the connection diagrams of this model series on page 3 "Connection diagram" and on the units' backs.
- Wire the cutter's connecting lead, such that it does not disturb any function of the assembly and that it will not be damaged or squeezed.

Preparations for use

(please observe the key of fig. „Designation of parts“ on page 2)

- Make sure that the cutter is turned off. Slide the paper in the paper feed direction indicated (10) through the paper channel (2). If the rotary knife (3) is not in home position it will hinder the paper strip from being slid through the channel.

You can put the rotary knife to home position in two different ways:

1. Insert a hex key, size 3, into the rotary knife's shaft (7) and turn the knife until it does not block the channel any longer. Then remove the hex key from the shaft!
2. Turn on the assembly and conduct one cutting cycle without paper.

Perform a trial run with paper.

Ensure that the paper strips are fed to the cutter continuously and properly and that the unit cuts them precisely.

Designation of parts

- 1 Paper cutter – type G model series
- 2 Paper channel
- 3 Rotary knife (not visible when type G)
- 4 Connecting leads
- 5 Connection diagram (not visible)
- 6 Identification (not visible)
- 7 Shaft of rotary knife with hexagon socket
- 8 Knife guard
- 9 Sense of the knife's rotation
- 10 Paper feed direction

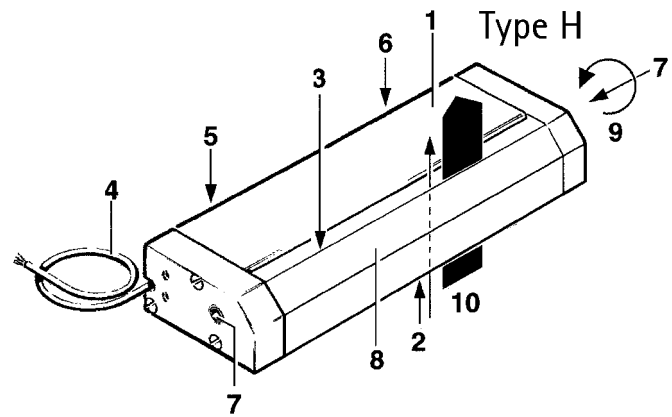

Control diagram

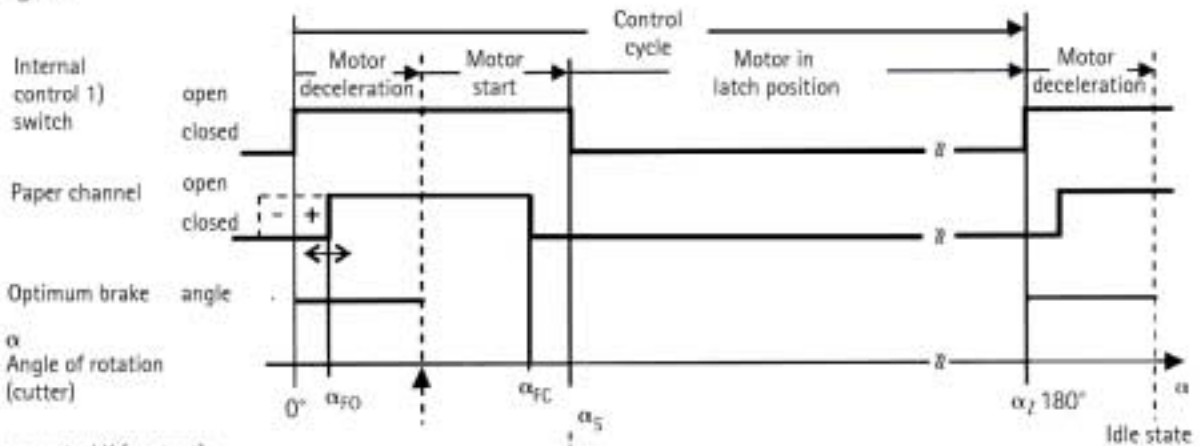

- 1) For trigger control K (contact):
Signal can be measured externally via connections yellow and brown
- 2) With standard switching

Current flow waveform

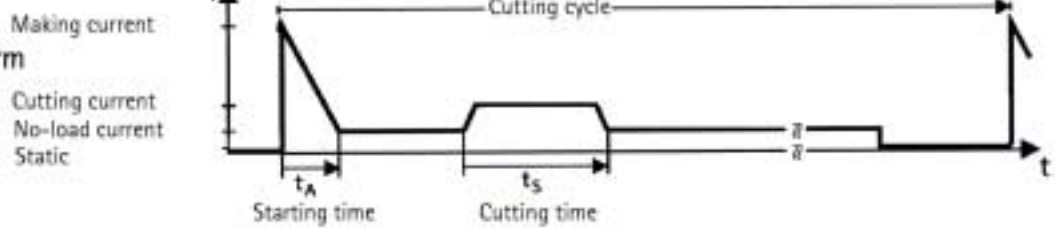

Connection diagram

Standard

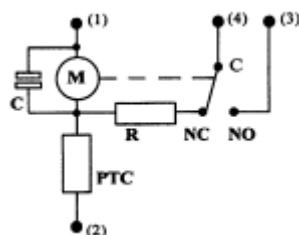

1 green
2 white
3 brown
4 yellow

Without internal switching

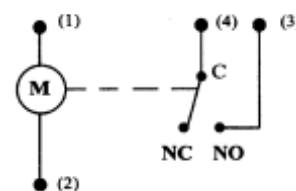

1 green
2 white
3 brown
4 yellow

Technical Data

	Standard	Without internal switching
Circuit diagramm	with internal switching and PTC (B)	without internal switching (C)
External start pulse by	SPDT contact, potential-free	-
pulse length	≥ 150 ms, ≤ 350 ms	-
switching level	operating voltage V_B	-
Cutting cycle max.	550 ms	550 ms
Operating voltage V_B	12 VDC/24 VDC (SELV)	12 VDC/24 VDC (SELV)
voltage tolerance	± 10 %	± 10 %
Current (at $T_U = 20^\circ\text{C}$)	$V_B = 12\text{ V} / V_B = 24\text{ V}$:	$V_B = 12\text{ V} / V_B = 24\text{ V}$:
static current	-	-
making current	2,2 A / 1,2 A	2,2 A / 1,2 A
no-load current	0,2 A / 0,13 A	0,2 A / 0,13 A
cutting current 1)	0,5 A / 0,3 A	0,5 A / 0,3 A
Failure (e.g. blocked knife)	2,4 A / 1,2 A ¹⁾	2,4 A / 1,2 A ²⁾
Climate		
operating temperature	-10 ... + 60 °C	-10 ... + 60 °C
storage temperature	-40 ... + 70 °C	-40 ... + 70 °C
medium relative humidity	65% without condensation	65% without condensation
Service life (number of cuts)	500.000	500.000
Permissible paper weight Type H		
L = 64 ... 120 mm	200 g/m ²	200 g/m ²
L = 140 ... 168 mm	160 g/m ²	160 g/m ²
L > 168 mm	80 g/m ²	80 g/m ²
Noise emission		
distance 30 cm, $V_B + 10\%$	75 dB (A)	75 dB (A)
General design	as per EN 60950, protection class III	as per EN 60950, protection class III
Protection class (IEC 529)	IP 10	IP 10
Vibration performance (IEC 68-2-6)	10 ... 60 Hz; 0,7 mm p.p. 60 ... 500 Hz; 50 m/s ²	10 ... 60 Hz; 0,7 mm p.p. 60 ... 500 Hz; 50 m/s ²
Shock resistance (IEC 68-2-27)	800 m/s ² ; 6ms	800 m/s ² ; 6ms
Drop test (DBP DIN ISO 2206, 2233, 2248)	passed	passed
Mounting	2 sunk nuts M3 (moveable)	2 sunk nuts M3 (moveable)
Paper		
channel width (L)	64; 90; 120; 140; 168 and 222 mm	64; 90; 120; 140; 168 and 222 mm
paper width	L-3 mm L-15 mm	L-3 mm L-15 mm
paper weight	60 ... 200 g/m ²	60 ... 200 g/m ²
Knife guard	standard	standard

1) After 10 seconds the PTC-resistor pull down the drive motor from operating voltage.

2) If the motor is jammed, the safety switching supplied by the customer must ensure that the power applied to the motor is limited after approx. 10 seconds.

Malfunctions

Result	Cause	Measure
Rotary knife does not move	-Operating voltage failure	-Check the power supply
	-Defective connecting cable	-Check the cutter's connecting cable as well as the plug-in and soldered connections
	-Defective trigger control	-Check mechanical resp. electronic pulsers
	-Rotary knife blocked by paper shreds/ foreign objects	-Switch off the appliance! Remove paper shreds from cutting area! Remove foreign objects!
	-Cause unknown	-Please contact the manufacturer
Rotary knife does not return to home position	-Defective reset switch or gear	-Please contact the manufacturer

Ordering Code

(see identification plate)

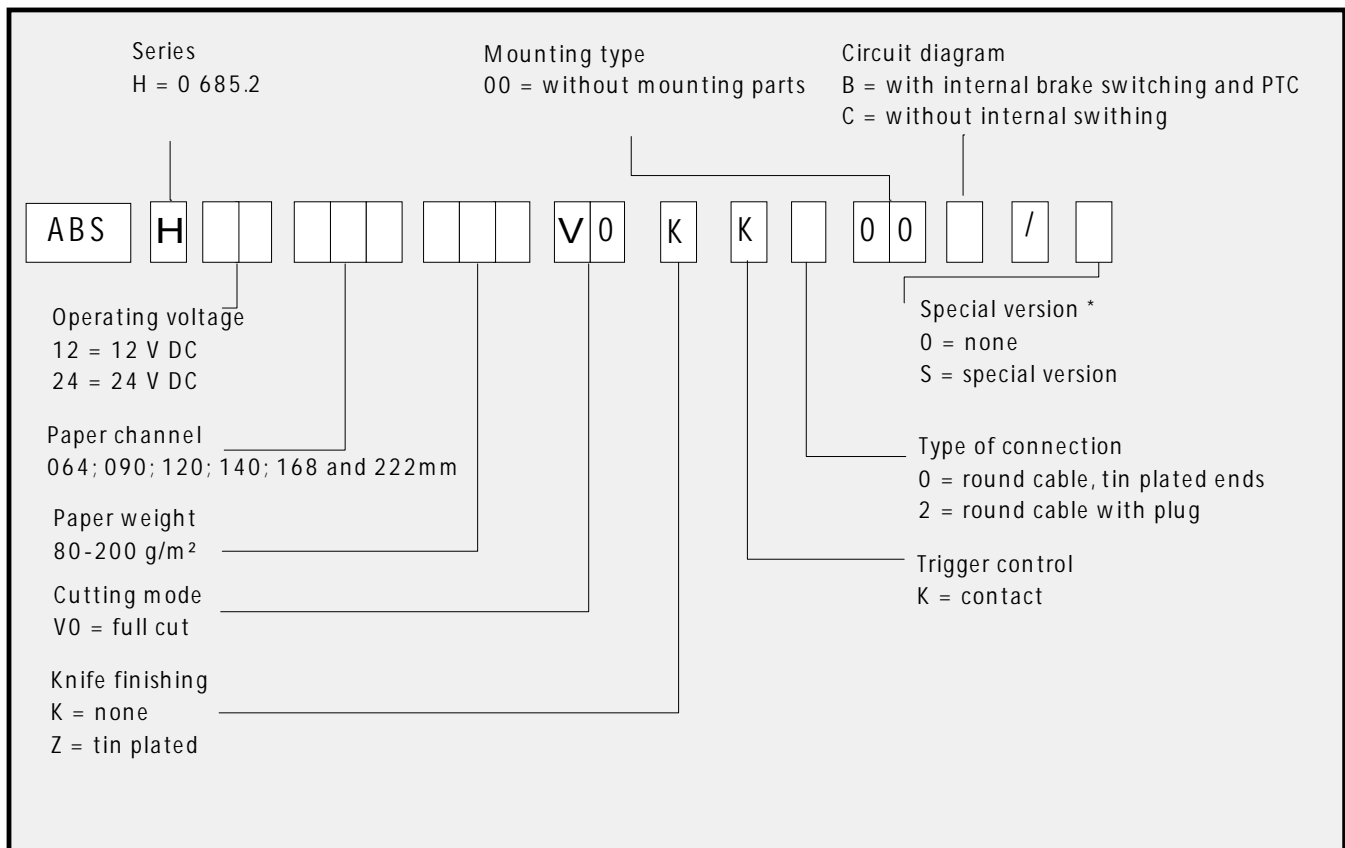

We apply customer specifications on special versions. If you don't know these please call us for the specifications, indicating the cutter's item number.

HENGSTLER GmbH
P.O.B. 1151
D-78550 Aldingen
Germany

Tel.: +49 (0) 7424 890
Fax: +49 (0) 74 24 89210
e-mail: info@hengstler.de
Homepage: <http://www.hengstler.com>